



**WELDLOGIC**  
FORMING & WELDING SOLUTIONS

WELDING SOLUTIONS  
FOR ADVANCED  
MANUFACTURING

PLASMA | TIG | LASER | MIG | SUB-ARC



## SEAM WELDER PLS-36 LONGITUDINAL

*Our PLS Weld Seamers are designed for straight line welding of all weldable metals in thicknesses from .015" to 3/8" and lengths up to 12 feet.*

The precision components and standard features of the PLS seamers provide a highly engineered complete platform for longitudinal welding. Optional features and available programmable welding controls provide unmatched capability for automating the welding process. Contact our engineers to receive free weld process evaluation and sample welds.

### APPLICATIONS

- Electric Motor Cases
- Filter Elements
- Automotive Exhaust
- Nuclear Vessels
- Vacuum Components
- Cryogenic Vessels
- Water Tanks
- Aircraft Components
- Coring Drills
- Flexible Metal Hose

# OPTIONS ▼

- Water -cooled Mandrel
- Insert gas back-up
- Automatic finger release
- Heavy-duty flexible cable track
- PLC Automation
- Loading cart
- Arc distance control
- Cold wire feed
- Video monitoring
- Laser seam tracking
- Riser blocks for larger diameters
- Position Based Control

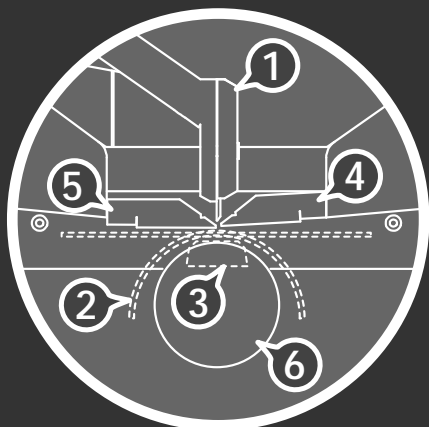

1. Alignment Gauge
2. Work piece
3. Back-up Gas Insert
4. Finger (Open)
5. Finger (Closed)
6. Mandrel (Water Cooled - Optional)

# SPECIFICATIONS ▼

Thickness Capacity	0.015" - 3/8"
Max. Diameter	32"
Torch Parallelism	± .003"
Speed Ranges	1.5 to 60 IPM
Speed Accuracy	± 0.1%
Input Power	220V 1-PH, 50/60 Hz
Compressed Air	80 psi



**WELDLOGIC USA**  
 2651 Lavery Court  
 Newbury Park, CA 91320  
 Tel. 805.498.4004 | Fax. 805.498.1761

WELDLOGIC.COM

# CONFIGURATIONS ▼

MODEL	MIN DIA	L	A	B	W	SHIP WT (LBS)
PLS-24	2.63"	27"	57"	65"	32"	1,213
PLS-36	3.50"	39"	69"	65"	32"	1,433
PLS-48	4.25"	51"	81"	68"	35"	1,654
PLS-60	5.23"	63"	93"	68"	35"	1,874
PLS-72	5.98"	75"	108"	68"	35"	2,315
PLS-96	7.25"	99"	129"	77"	41"	2,535
PLS-120	9.48"	123"	161"	77"	41"	2,756
PLS-144	12.25"	147"	182"	77"	41"	3,025

For special requirements please contact Weldlogic.

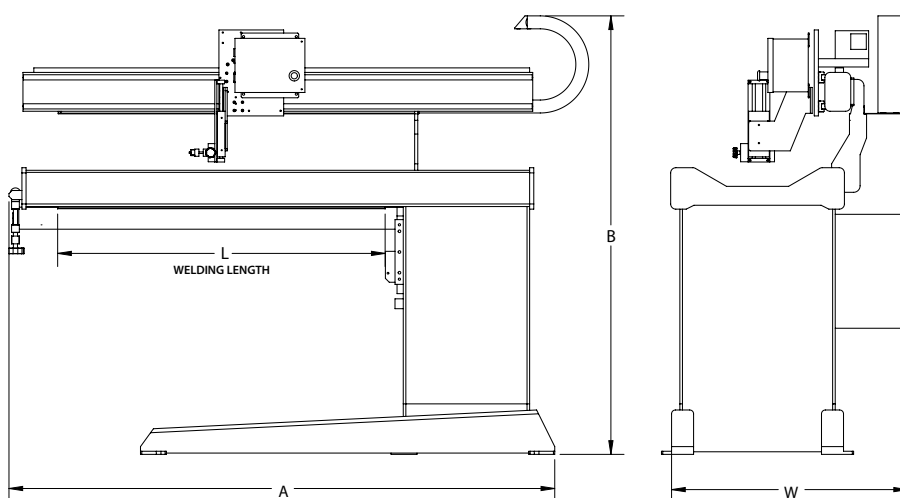

- AC Servo Carriage Drive Motor
- Reversible Copper Fingers
- Copper Back up bar with Gas Purge capabilities
- Air Actuated retractable Edge Squaring Device
- Foot Pedal Finger Clamping Actuation
- Independent left and right actuation
- Torch Mount with Cross Seam Adjustment & Automatic Pneumatic Torch Retract
- Precision Ball Bearing Linear track for smooth travel
- Fully Welded Fabrication
- Split Base Foundation
- Allowing to add Riser blocks for larger diameters
- Mandrel end latch safety switch
- Mandrel Vertical adjustment for various thicknesses
- Weld Process Development & Support

**STANDARD FEATURES**

## WELDLOGIC EUROPE

Blackstone Road, Huntingdon  
 Cambridgeshire, PE29 6EF, UK  
 Tel. 01480 437478 | Fax. 01480 437479