

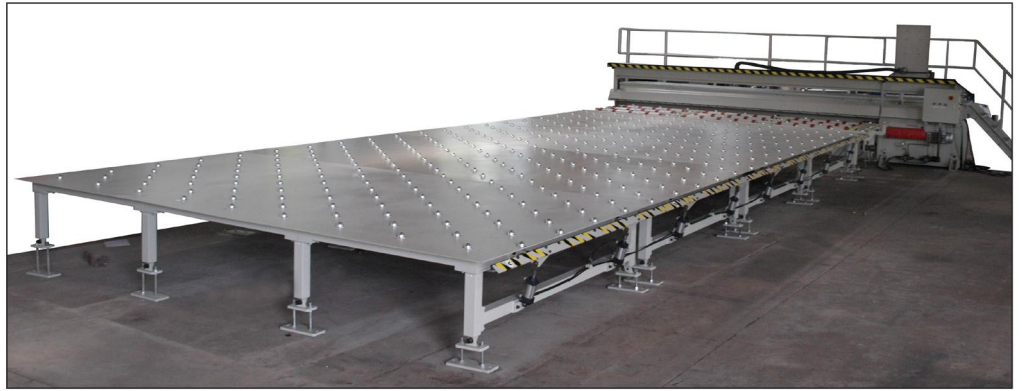

PLS-180 Longitudinal Seam Welder



- Plasma
- Tig
- Laser
- Mig
- Sub-Arc



Weldlogic PLS Weld Seamers are designed for straight line welding of all weldable metals in thicknesses from .005” to 1/2” and lengths up to 15 feet.

The precision components and standard features of the PLS seamers provide a highly engineered complete platform for longitudinal welding. Optional features and available programmable welding controls provide unmatched capability for automating the welding process.

Contact our engineers to receive free weld process evaluation and sample welds.

PARTIAL APPLICATIONS LIST

- Electric motor cases
- Filter elements
- Automotive exhaust
- Nuclear vessels
- Vacuum components
- Cryogenic vessels
- Water tanks
- Aircraft components
- Coring drills
- Flexible metal hose

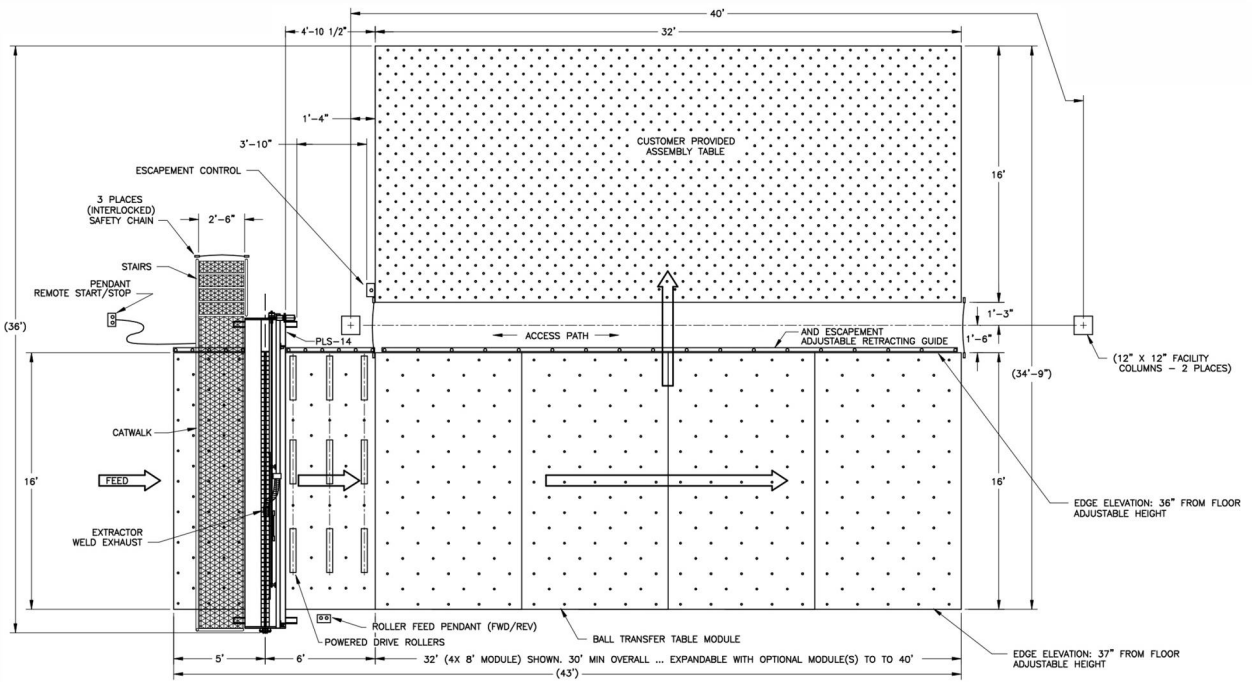
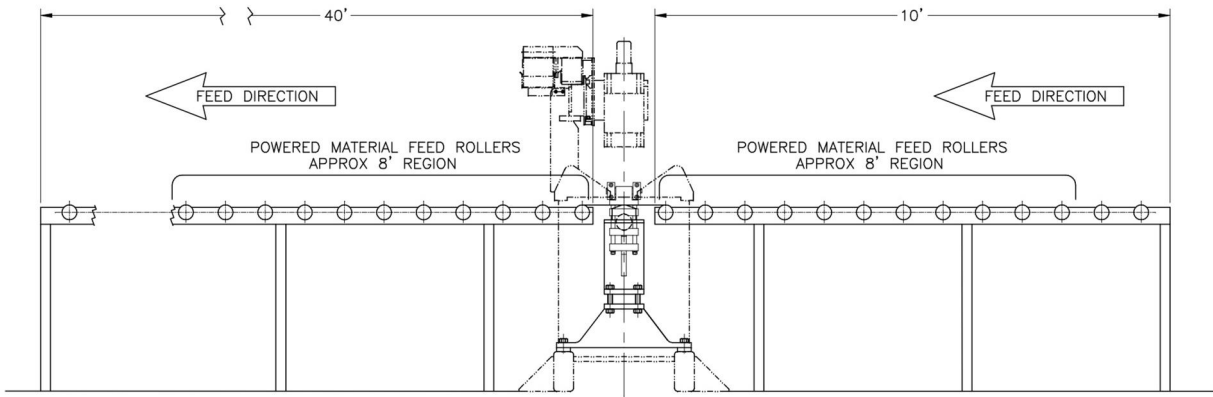
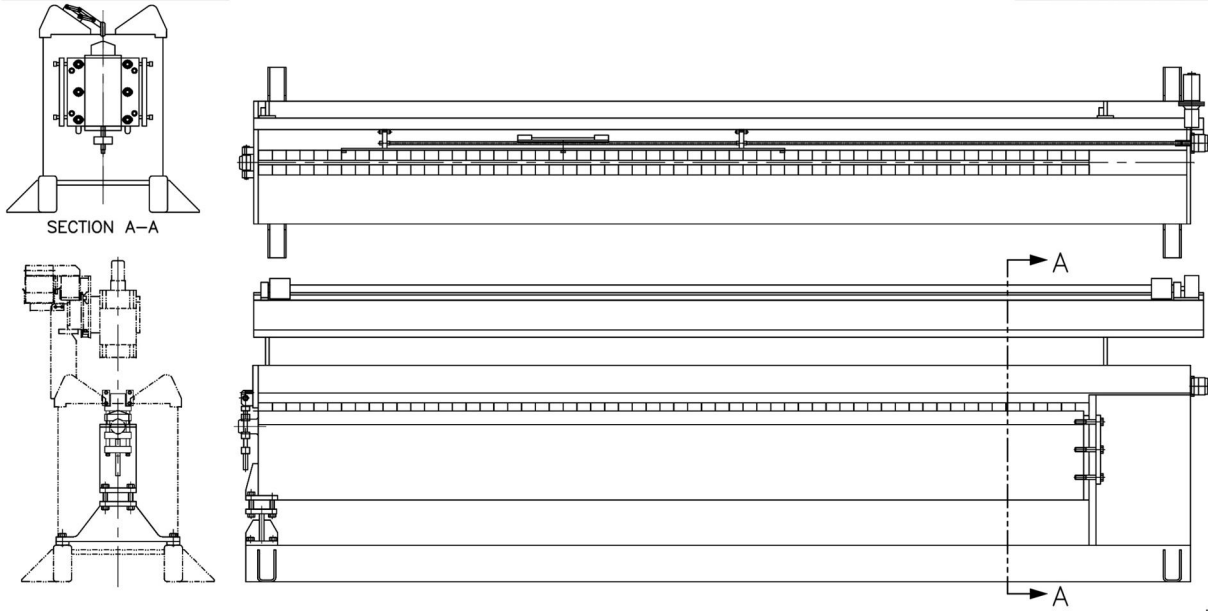

STANDARD FEATURES INCLUDE:

- AC Servo Carriage Drive Motor
- Reversible Copper Fingers
- Copper Back up bar with Gas Purge capabilities
- Air Actuated retractable Edge Squaring Device
- Foot Pedal Finger Clamping Actuation - Independent left and right actuation
- 8" Square Torch Mount with Cross Seam Adjustment and Automatic Pneumatic Torch Retract
- Carriage mounted Microprocessor Controller
- Precision Ball Bearing Linear track for smooth travel
- Fully Welded Fabrication
- Split Base Foundation - Allowing Owner to add Riser blocks to accommodate larger diameters
- Mandrel end latch safety switch
- Mandrel Vertical adjustment for various thicknesses
- Weld Process Development & Support

OPTIONS

- Water-cooled Mandrel
- Insert gas back-up
- Automatic finger release
- Heavy-duty flexible cable track
- P.L.C. Automation
- Loading cart
- Arc distance control
- Cold wire feed
- Video monitoring
- Laser seam tracking
- Riser Blocks for larger diameters
- Position Based Control

Model	Min Dia.	L	A	B	W	Ship Wt (lbs)
PLS-24	2 5/8"	24"	57"	65"	32"	1,975
PLS-36	3 1/2"	36"	69"	65"	32"	2,200
PLS-48	4 1/4"	48"	81"	65"	32"	3,525
PLS-60	5 1/4"	60"	93"	65"	32"	4,175
PLS-72	5 1/4"	72"	107"	68"	36"	4,625
PLS-84	6 7/8"	84"	126"	68"	36"	4,950
PLS-96	7 1/4"	96"	145"	68"	36"	5,300
PLS-120	9 1/2"	120"	161"	77"	41"	8,800

Contact Weldlogic for your special requirements

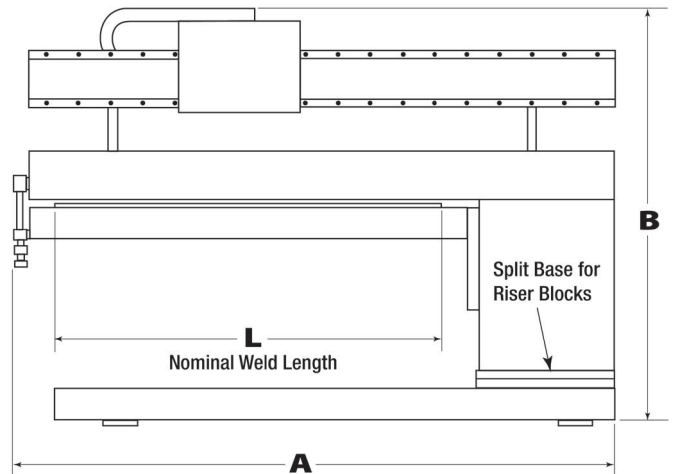
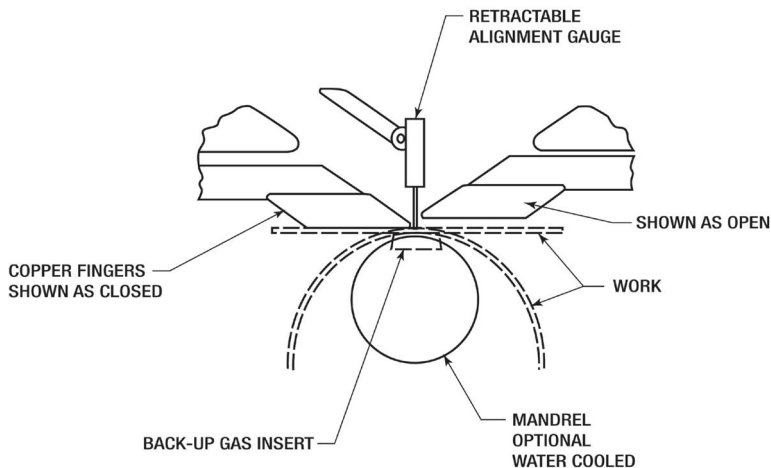
W = Overall Width

SPECIFICATIONS

Thickness capacity:	0.005" - 1/2"
Maximum diameter:	32"
Torch parallelism:	± .003"
Speed ranges:	1.5 to 60 IPM/3.0 to 120 IPM
Speed holding accuracy:	± 0.1%
Input power requirements:	220v 1-ph, 50/60 Hz
Compressed air:	80 psi

Weldlogic USA Engineering & Mfg.

 2651 Lavery Court, Newbury Park
 CA 91320, USA
 Tel. (805) 498-4004 | Fax. (805) 498-1761

Weldlogic Europe

 Blackstone Road, Huntingdon
 Cambridgeshire, PE29 6EF, UK
 Tel. 01480 437478 | Fax. 01480 437479